

Compact Dome IP Camera

Description of The Device

The component parts (the internal view).

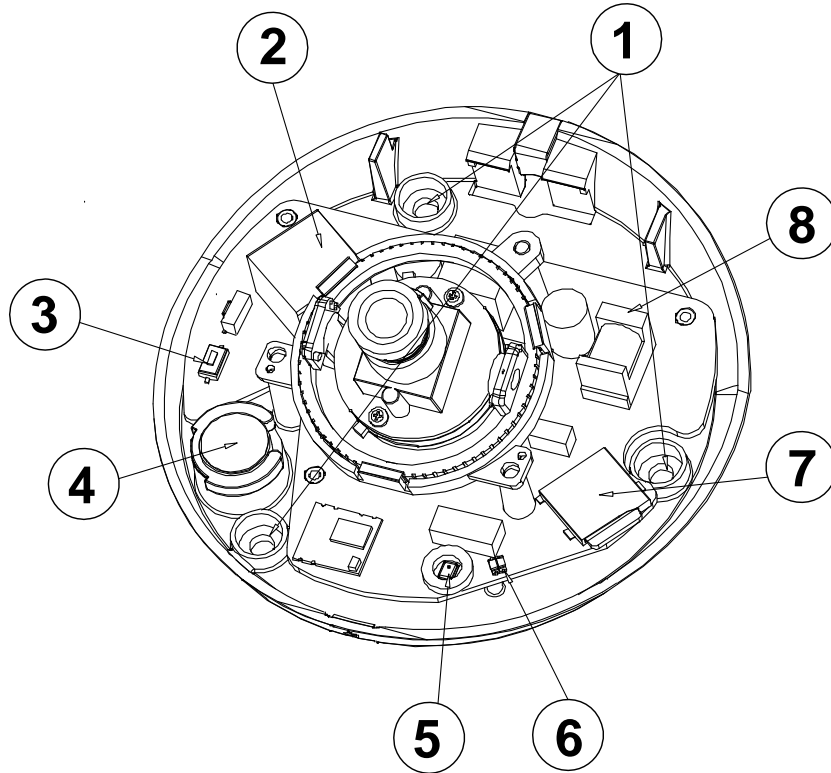

1. **Screw holes:** Guide to assist correct casing alignment with the cable channel.
2. **ETHERNET 10/100 Connector:** This is a standard RJ-45 connector for 10/100 Mbps Ethernet networks. PoE (Power over Ethernet) function: Provides power to the device via the same cable as used for the network connection.
3. **Reset button:** Recover to factory default..
4. **Speaker:** Connector is used to connect the audio output from other devices to the camera.
5. **Microphone:** The built-in microphone records audio of the surrounding area.
6. **LED indicator:** The Power and network indicator.

7. **Micro SD CARD slot:** Insert a Micro SD card for Local storage for storing recorded image and video. This is used for updating system software and archiving / accessing critical images.
8. **DC-in:** Connects to 12 V DC power.

Camera (the external view).

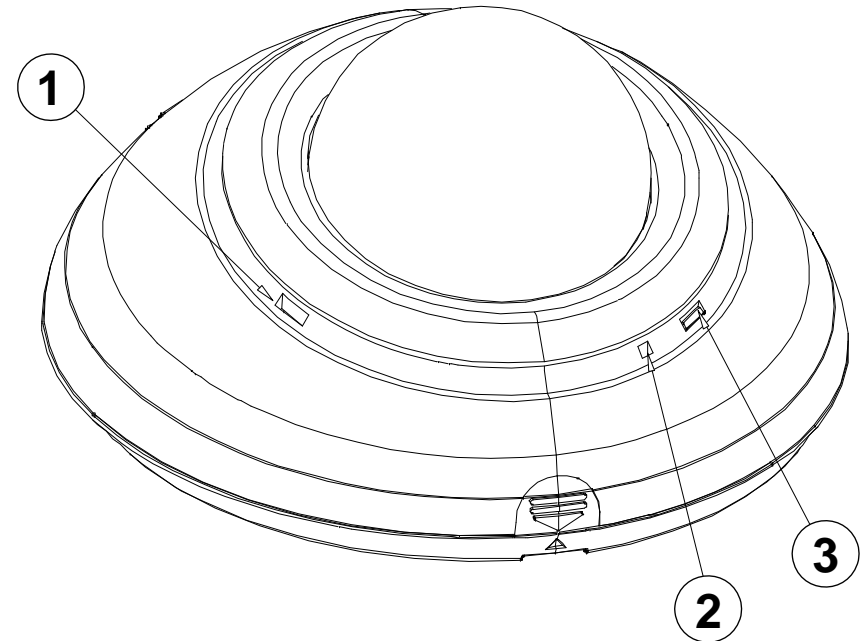

1. **Speaker:** Connector is used to connect the audio output from other devices to the camera.
2. **Microphone:** The built-in microphone records audio of the surrounding area.
3. **LED indicator:** The Power and network indicator.

How to install an SD card?

Step 1: Place the camera face down on a non-slip flat surface.

Step 2: Open the camera enclosure. Lift the dome off the base of the camera.

Step 3: Push the SD card into the camera with the gold contacts oriented towards the base of the camera. To eject the SD card, push the SD card into the slot.

Step 4: Replace the dome enclosure ensuring a tight fit.

NOTE: To ensure that the camera stays weatherproof, users are advised to ensure that the weatherproof sheath is secured firmly in place.

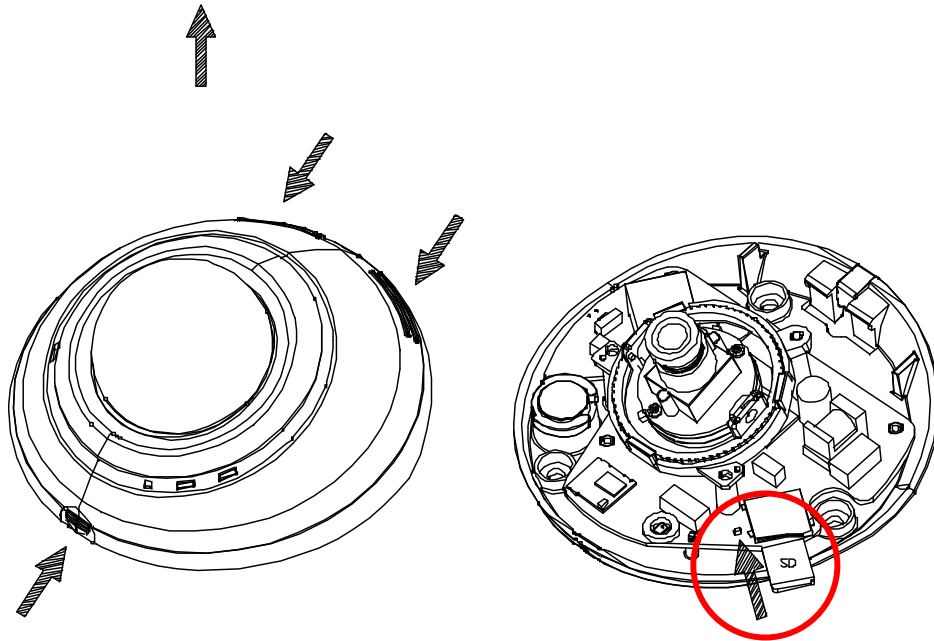

Camera Mounting:

Step 1: Position the alignment sticker in the desired location for the camera.

Step 2: Use a 6mm drill bit to make required holes approximately 25mm deep.

Step 3: Insert wall anchors.

Step 4: Affix the camera base using the screws provided.

Step 5: Adjust the Lens.

Step 6: Affix the dome using the screws provided.

Step 7: Insert the weatherproof rubber screw coverings over the screws ensuring a tight seal.

Step 8: Using the Ethernet cable connect to the Ethernet port. Connect the other end of the Ethernet cable your network. If you are using a PoE hub, connect the IP camera to the hub via an Ethernet cable, which will provide transmission of both power and data over a single cable.

Step 9: Connection with 12V DC Power Adaptor.



Figure. 1

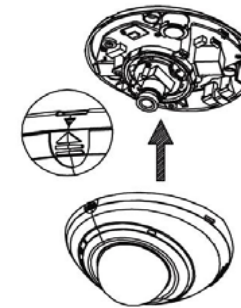

Figure. 2

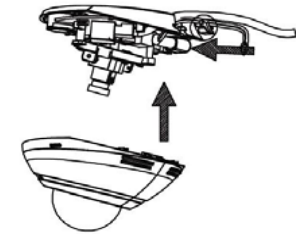

Figure. 3

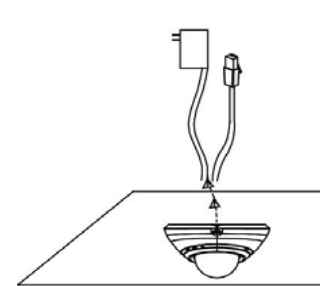

Figure. 4

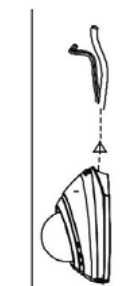

Figure. 5



Figure. 6

Please follow the steps given below to install, configure and set the IP Camera.

1. Check the IP class of your PC

Step 1: From the **Start** menu, point to **Settings**, and then click **Control Panel**.

Step 2: When **Control Panel** appears, double-click the **Network Connections** icon. The **Network Connections** dialog box appears.

Step 3: Click the **Protocols** tab in the **Network Connections** dialog box.

Step 4: When the **Local Area Connection Properties** dialog box shows up, choose **Internet Protocol (TCP/IP)** and click **Properties**.

Step 5: In the **Internet Protocol (TCP/IP) Properties** dialog box, choose **Use the following IP Address** to indicate that you do not wish to use DHCP, and assign IP Address 192.168.1.200 with Subnet mask 255.255.255.0. Click **OK** when you finish it.

Step 6: Choose Close to finish the modification.

2. Install UPnP Packets of your PC

As described before, Microsoft Windows XP[®] doesn't start the UPnP service by default; however, we have to install some packets before we initialize it. The following steps will help you to install them.

Step 1: From the **Start** menu, point to **Set Program Access and Default**, and then click it.

Step 2: When the **Add or Remove Programs** dialog box appears, click the **Add/Remove Windows Components** button.

Step 3: Check the **Network Services** in the **Windows Component Wizard** dialog box, and then click **Details....**

Step 4: Check **UPnP User Interface**, and choose **OK**.

Step 5: When the original **Network Component Wizard** dialog box returns, click **Next**.

Step 6: After about one minute the UPnP installation will be done, and choose **Finish** to close it.

3. Turn on Services of your PC

After installation, we should turn on the relative services to start the UPnP protocol. The following procedures will teach you how to do it.

Step 1: From the **Start** menu, point to **Settings**, and then click **Control Panel**.

Step 2: When **Control Panel** appears, double-click the **Administrative Tools** icon. The **Administrative Tools** dialog box appears.

Step 3: Click the **Services** icon in the **Administrative Tools** dialog box.

Step 4: When the **Services** dialog box shows up, double click the **SSDP Discovery Service** icon.

Step 5: Choose **Automatic** in the **Startup type**, and click **OK** to start it.

Step 6: When the **Services** dialog box appears again, double click the **Universal Plug and Play Device Host** icon.

Step 7: Choose **Automatic** in the Startup type, press the **Start** button, and click **OK** to start it.

Step 8: Restart your system.

4. Set the static IP address in the IP Camera.

Step 1: Plug in its power connection.

Step 2: Plug the USB connector in your PC and in the USB socket in the rear of the lens.

Step 3: A window pops up asking if you want to "Run the program", "Open folder to view files", or "Take no action". Choose "Run the program" and click "OK", and the "USB configuration" window will pop up.

Step 4: Set the Network setting and type in the IP address you desire. Before you change the IP address, you should note the factory default Static IP address (192.168.1.168).

Step 5: After changing the IP address, click the "**Apply**" button in the "**USB Configuration**" window.

Step 6: A message pops up asking you to affirm the action as "**OK**".

Step 7: Click "**OK**", and remove the USB connection from your PC.

Step 8: Click "**Exit**" at the bottom of the "**USB Configuration**" window to close the window. Or, choose the "**Launch**" button to see the local camera images directly.

Step 9: Before clicking "**Launch**", check your PC's IP address and use the Network connector (RJ-45) to link up with your camera.

Step 10: If you can see the images, it means the IP setting is complete.

5. Scan IP Camera through "My Network Place"

Step 1: After your installation and starting services, the UPnP protocol will take effect. You can scan all **IP Cameras** in My Network Place.

Step 2: Just double click the **IP Camera** icon, and the video live stream will pop up automatically without assigning any IP address in Microsoft Internet Explorer.

6. Change the IP Camera's control and operational settings.

Step 1: Type in the IP address in the IE Browser. You will now see the IP camera' images.

Step 2: Use the buttons below the images to enter any other operational settings pages.

Step 3: When you change any setting, please don't forget to click the "**Submit**" button in each page.

NOTE: Enable DHCP Function: This function can only work if the LAN, which the unit is connected to, has a DHCP server. If the DHCP server is working, the IP Camera will obtain an IP address automatically from the DHCP server.

NOTE: When only one unit of the IP Camera is connected to a computer or LAN, you can freely assign an IP address for the IP Camera. For example, there is a range of IP Camera IP addresses from 192.168.1.1 to 192.168.1.255. You can pick one for use from the range of the IP. It's not necessary to set MASK and GATEWAY; leave the settings as default.

When an IP Camera is connected to a WAN, you must acquire a unique, permanent IP address and correctly configure the MASK and GATEWAY settings according to your network architecture. If you have any questions regarding those settings, please consult a qualified MIS professional or your ISP.

NOTE: Assemble the camera

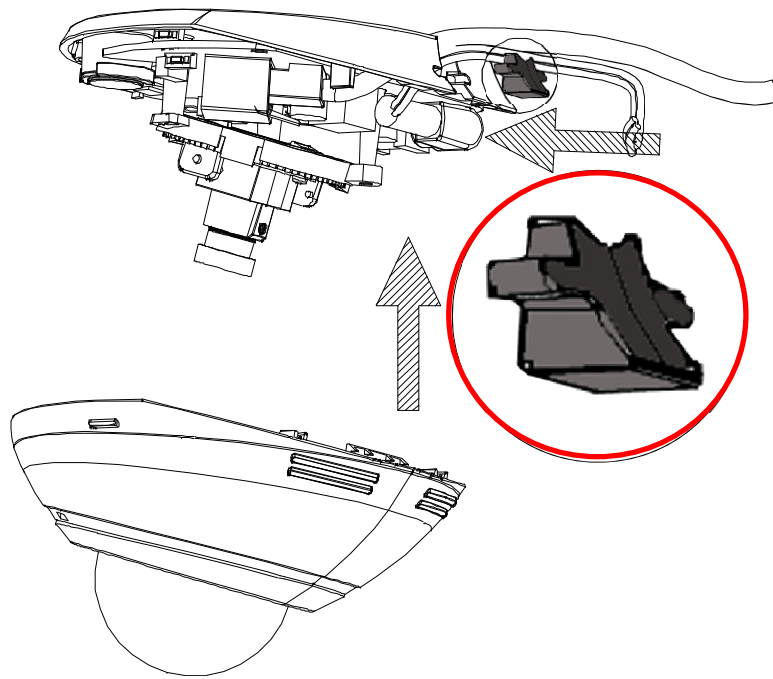

1. Remove the dome cover.
2. Remove the black tenon as shown the figure above.
3. Connect the cables.
4. After connecting the power and the Ethernet cables, please make the mortise and tenon joint.
5. Seat the dome cover.

WARNING

- To prevent fire or shock hazard, avoid exposing this unit to rain or moisture.
- Do not block ventilation openings.
- Do not place anything on top of the unit that might spill or fall into it.
- Do not attempt to service this unit yourself, as opening or removing covers may expose you to dangerous voltage or other hazards. Please refer all servicing to your distributor / retailer.
- Do not use liquid cleaners or aerosols for cleaning.
- To prevent fire or electric shock, do not overload wall outlets or extension cords.
- PoE warning : If the PoE injector is used instead of the supplied power adaptor, all of the wiring to and from the injector must be routed/ installed inside a building/ plant and never routed/ installed outside of the building/ plant.
- Please only select a power adaptor or power certified by UL and marked at 24Vac / 60 Hz, minimum 1A, class 2 or LPS.
- The interconnecting cables should be placed inside the UL certified Outdoor Use Conduits.
- If the power supply is installed outdoors, it should be a listed rainproof / watertight class 2 / LPS power supply or a listed power supply complying with UL60950 -1, part 1 and part 22.
- The wiring method should comply with article 725 and article 300 in the national electrical code for the class 2 circuit and wiring in duct.
- The entire installation should be performed by qualified personnel.
- Please do not look directly at the shining, reflecting surface of the camera housing. Looking directly could result in eye uncomfortable.
- This product should not be used for the same purposes as consumer electronic devices.

CAUTION

RISK OF EXPLOSION IF BATTERY IS REPLACED BY AN INCORRECT TYPE. DISPOSE OF USED BATTERIES ACCORDING TO THE INSTRUCTIONS.

Specifications

Model	Compact Dome IP Camera	
Camera	Lens	Fixed Focal Board Lens f:3.6mm F1.8.
	3-axis Angle (non-motorized)	Vertical: 30°; Horizontal: 90°; Rotational: 180°
Image	Video Compression	H.264/ MJPEG.
	Resolution	"4:3": 960x720, 800x592, 640x480, 480x360, 320x240. "16:9": 1280x720, 800x448, 640x360, 480x272, 320x176.
	Video streaming	NTSC: Maximum 30FPS (1920x1080) PAL: Maximum 25FPS (1920x1080)
	Profiles	2 (selectable)
	Image settings	- Adjustable image size, quality, and bit rate. - Day / Night mode. - Flip & Mirror. - AGC, AWB, AES. - Time stamp and text caption overlay. - Privacy masks. - Exposure Mode
	Video management software	SDK, including HTTP-API / ActiveX / ONVIF.
Audio	Audio streaming	Two-way.
	Compression	G.711
	Audio bit rate	G.711 64kbps
	Inputs / outputs:	Build-in Microphone & Speaker (5M).
Network	Security	Multi-level password protections, IP address filtering, HTTPS encryption, User access log.
	Protocols	IPv4, HTTPS, HTTP, TCP, UDP, RTP/RTCP/RTSP, DHCP, NTP, FTP, SMTP, UPnP, ICMP, ARP, DDNS, PPPoE, SAMBA
	Users	Access by 10 simultaneous users.
	Firmware update	SD card / HTTP.
Alarm	Recording	SD card
	Pre-alarm recording	Yes.
	Advanced motion	512 zones. Sensitivity: 0 - 100 %.
	Trigger	Motion Detection Schedule Alarm input Ethernet loss
	Notification	SD card recording, SMTP, FTP, HTTP
Connectors	RJ-45	10 BASE - T / 100 BASE -TX.
	DC-Jack	φ 6.5x2.0.
	Reset	Reset for factory default.
	Local storage device	Micro SD card slot
General	LED indicators	Network / Power
	Power	- 12V DC (DC power jack). Approx. 6 W. - PoE: IEEE802.3af compliant 802.3af. Class 2
	OS	Linux 2.6 kernel.
	Operating conditions	-0°C to 50°C (32°F to 122°F)
	Approval	CE, FCC, RoHS
	Dimensions / Package Weights	60 x 107 mm./ 710g.
	Accessories included	- Quick Installation Guide. - CD x 1 (includes User's Manual). - Power adapter: (Input: 100-240 VAC, 50 / 60 Hz, Output: 12VDC, 1.5A). - RJ-45 cable x 1

*Specifications are subject to change without notice.